

SYPHON -COIL /PIG TAIL / U TYPES SSKE30-2

APPLICATIONS

- Max. Working Temperature 400°C
- Max working pressure 160 bar
- Heat Reducer for Instruments
- High-pressure & vibration applications

FEATURES

- Seamless pipes construction
- Boiler and High Temperature fittings
- 3 different loop designs



COIL TYPE

PIG TAIL TYPE

U TYPE

SYPHON -COIL / PIG TAIL / U Type , SSKE30-2

DESCRIPTION

General

Thread design : ANSI B1.20.1 / BS EN ISO 228-1

Service temperature : PT Chart

Working Pressure : PT Chart

Standard version

Syphon type : Coil / Pig Tail / U Type

Instrument connection : 1/2" NPT (F) / 1/2" BSP (F)

Process connection : 1/2" NPT (M) / 1/2" BSP (M)

Material of construction

Pipe material : AISI 304 SS / AISI 316 SS / BRASS / CS

GA DRAWING

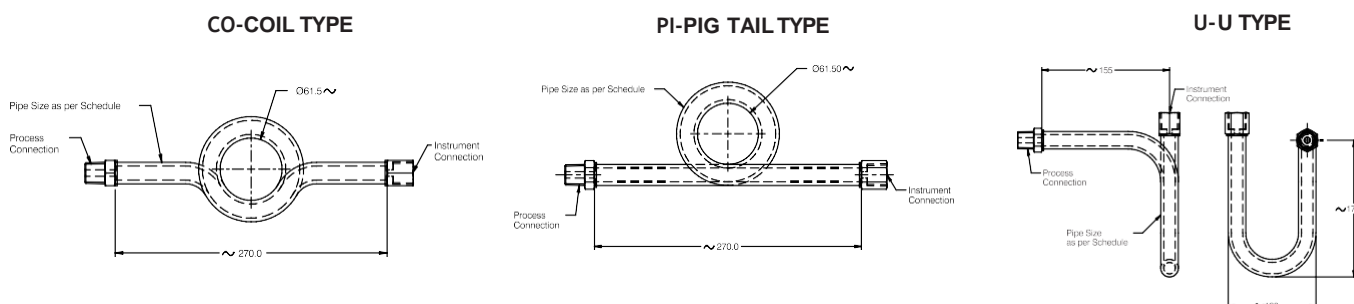

ORDERING CODES

MODEL SSKE30-2-Syphon

SSKE30-2

BODY MATERIAL

CO

CO-COIL TYPE

PI-PIG TAIL TYPE

U-U TYPE

BODY MATERIAL

S01

S01 AISI 304 SS

S02 AISI 316 SS

S24 BRASS

INSTRUMENT CONNECTION

P27

P28 1/2" NPT (F)

P23 1/4" BSP (F)

P27 1/2" BSP (F)

P24 1/4" NPT (F)

PROCESS CONNECTION

P07

P04 1/4" NPT (M)

P08 1/2" NPT (M)

P03 1/4" BSP (M)

P07 1/2" BSP (M)

P04 1/4" NPT (M)

OPTIONS

E90

E90 HYDRO TEST CERTIFICATE

E31 Material test certificate 3.1

E32 Material test certificate 2.2

Ordering Example : SSKE30-2.CO.S01.P27.P07.E90/XX.

SHREE SAMARTH KRUPA ENGINEERS

Contact : +91 8155865961, +919586682557

prakash@shree-samarthkrupa.com, www.shree-samarthkrupa.com